

Design and Analysis of Automatic Car Park System with Capacity Control

Musa Mohammed Gujja & Umar Abubakar Wakta

Department of Electrical and Electronic Engineering Ramat Polytechnic Maiduguri

Abstract: The need for an automatic car park gate system has been in increase in recent times following the economic situation in present days. The circuit is aimed at eliminating manual operation of a car park. It incorporate the use of LM741 op-amp and CD4017 decade counter for controlling the number of vehicle that can have access to the parking premises and the circuit is fixed close to the gate with the sensor tragically located where it can sense the presence of a car. The light dependent resistor (LDR) senses both entrance and exit of the cars and this followed the maximum of three cars in the case of this design. As a monitoring and control system, when you comes close to the gate the light dependent resistor senses an incoming car which allows the gate to open automatically and closed when done. This process is same for outgoing cars. This module make use of an optical sensor, whose resistance changes with the intensity of light (Horowitz, 1980) the type use is ORP12 and it has a dark resistance of 10MΩ. When light rays are focused on the light dependent resistor (LDR), the resistance becomes very low (0-500Ω) but when the rays are interrupted, the increases to its dark resistance (Huiyu, 2010). The variable resistor is used to vary the sensitivity of the light dependent resistor. It is otherwise called dark activated sensor. For the design two conditions are considered. First, when light rays are focused on the ORP12, and second, when the rays are being interrupted. The counter registers and displays the number of vehicle crossing the gate (both entrance and exit) and allows maximum of three cars. Once the maximum is reached, the gate entrance remains closed and inaccessible, until another vehicle leaves the park. The car park system comprises of the sensor unit, trigger circuitry, display unit (switching unit) and the power supply unit.

Keywords: Sensors, display, control, trigger

1.0 INTRODUCTION

An ideal solution for today's car parking and traffic problems in cities is the automatic car parking system which offers utmost efficiency, convenience, safety and reliability. Automated car parking is a method of automatically parking and retrieving car that typically use system pallets and lifts. The intension is to compact more cars in the same space, reduce the space needed to park the same number of cars. An automatic car park can be situated above or below or a combination of both. The need for automatic car park gate system has been on the increase in recent times. The system describe here automate the entrance to parking lots of residential home; organize automobile terminus and public car parks. The technology used, eliminate gate monitoring and manual opening and closing by human beings.

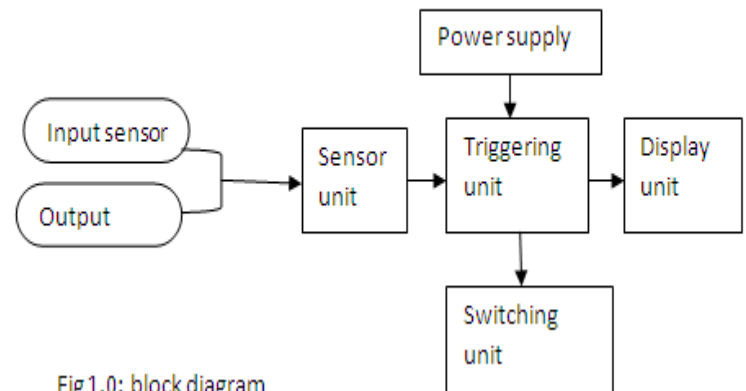

Fig 1.0: block diagram

2.0 CAPACITOR

A capacitor (formally known as condenser) is a passive electronic component consisting of a pair of conductors separated by dielectric (insulator). When there is a potential difference (voltage) across the conductor, a static electric field develops in the dielectric that stores energy and produces a mechanical force between the conductors. An ideal capacitor characterize by a single constant value, capacitance measured in farad. Capacitor are widely used in electronic circuit for blocking direct current while allowing alternating current to pass, in filter network, for smoothing the output of power supplies, in the resonant circuit that radios to a particular frequency and for many other purposes.

2.1 IC VOLTAGE REGULATOR

IC voltage regulators are the three terminal device that provide a constant DC output voltage that is independent of the input voltage, output load current and temperature. There are three type of IC (integrated circuit) voltage regulators (Cathey, 2002), IC linear voltage regulators, IC switching voltage regulators, and DC/DC converter chips. IC linear voltage regulators use an active pass element to reduce the input voltage to a regulated output voltage. By contrast, IC switching voltage regulators store energy in an inductor, transformer, or capacitor and then use this storage device to transfer energy from the input to the output in discrete packet over a low resistance switch. DC/DC converter chips, a third type of IC voltage regulator, also provide a regulated DC voltage output from a different unregulated input voltage. In addition DC/DC converter provides noise isolation regulated power buses. For each type of IC voltage regulator, the output voltage can be fixed or adjusted to a value within a specified range (Vodovozou, 2010).

3.0 THE POWER SUPPLY UNIT

The DC power supply in this design consists of transformer rectifier and voltage divider to achieve stepping the 220v AC to 12v and rectifying the AC voltage to DC (Willey, 1969). This employ full wave bridge rectifier for it has several advantages over the centre tap transformer (Ramsy, 1983). Below is some advantage of bridge rectifier.

- I. Non centre tap is requiring on the transformers.
- II. Much smaller rectifier are required.
- III. It has low peak inverse voltage (PN) meeting per diode, the obvious disadvantage is not normally fact, and since the availability of low last silicon diode has made it more economical.

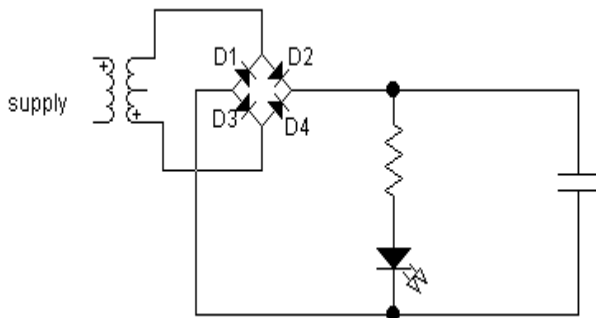

Fig 3.0: power supply unit

Consequentially point A of the bridge rectifier always act as an anode and point C as cathod.The input frequency is twice that of the supply frequency.

$$2\frac{\sqrt{2V_{ac}}}{\pi} = V_{dc} \text{ full wave} \text{-----} 1$$

$$\text{Like wise } 2\frac{\sqrt{2I_{ac}}}{\pi} = I_{dc} \text{ full wave} \text{-----} 2$$

It can be establish that

$$V_{dc} = \frac{2V_n}{\pi} \text{-----} 3$$

But

$$V_n = \frac{\sqrt{2r_{ms}}}{\pi} \text{-----} 4$$

Therefore

$$V_{dc} = 2\sqrt{2r_{ms}} \text{-----} 5$$

At the secondry of the transformer

$$V_{ac} = 12v \text{-----} 6$$

$$I_{ac} = 300mA = 0.3A \text{-----} 7$$

From equation 1

$$V_{ac} = \frac{2\sqrt{2V_{ac}}}{\pi} \text{ therefore}$$

$$\frac{2\sqrt{2 \times 12}}{\pi} = 10.8v \text{-----} 8$$

Similarly from equation 2

$$\frac{2\sqrt{2I_{ac}}}{\pi} = \frac{2\sqrt{2 \times 0.3}}{\pi} = 0.27A \text{-----} 9$$

3.1 THE TRIGGERING UNIT

This unit consist of operational amplifier LM741 that compare two levels input and gives an output representation of the input .The triggering unit is base on pulse trigger that respond to pulse or level change and gives out pulse (Ramsy, 1983).The pulse from the triggering unit is being fed to the input clock of the counter. A trigger can be any respond circiut that senses the present or difference of pulse and send an output that is relative to the input depend on the requirement.

3.2 COMPARATOR/VOLTAG SENSOR UNIT

The comparator/voltag sensor stage comprises of the two voltages at the input and gives an output between two levels high and low (Windfield, 1980). The input to the inverted input is set on the supply voltage using a variable resistor to select the preset level which present the input sensing respond level. It is connected to regulate 5V to ground.

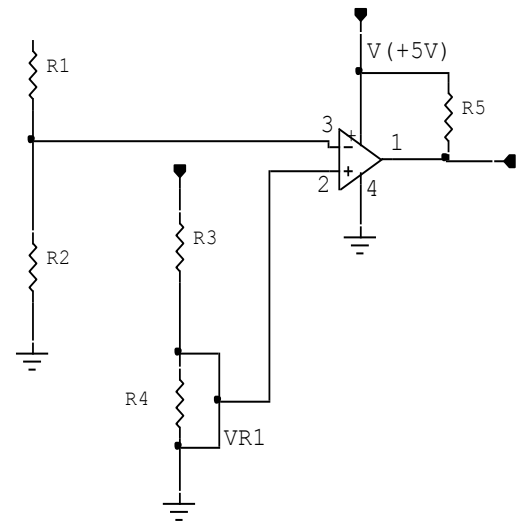

Fig 3.1: comparator stage

When light rays of great intensity are focused on the ORP12 the output voltage, V_{01} and V_{02} are low (approximately 0v). When the light beams are interrupted, the output voltage increases to 5v approximately (Horowitz, 1980).The circuit has the ability to detect only the passage of an automatic through the entrance and exit gates. Each pair of sensor are separated by a reasonable distance such that the passage of a person or other moving object cannot obstruct the sensor pair separator. If this happens, only

one sensing unit is activated and is processed by the trigger circuitry so that there will be no triggering (Cathey, 2002). Also, the height of the sensors is considered such that only the body of a vehicle can interrupt the light beams of the sensor and not the tires or it's windows.

3.3 THE COUNTER UNIT

The counter unit consists of a decade counter CD4017 use to count and encode the binary code to display unit (Horowitz, 1980) each and every time the sensor unit is triggered by the car. The decade counter CD4017B is a 5 stage divided by 10 counter with ten decoded outputs (Vodovozou,2010). The counter cleared its zero count by a logical "1" on their reset line. This counter is advanced on the positive edge of the clock signal when the clock enable signal is in the logical "0" state. Its configuration permits medium speed operation and assures a hazard free, counting sequence. The ten decoded outputs are normally in the logical "0" state only at their respective time slot. Each decoded output remains high for 1 full clock cycle. The carryout signal completes a full clock cycle for every ten clock input cycles and is used as a ripple carry signal to any succeeding stages. It consist of four divided configure to give binary code 1-3 to the decoder driver each divide conduct to the pulse provide by the decade output using the influence of the clock input at it base and send a pulse to the right input binary. These devices used forward register to count the input responds. The device has a medium speed operation. The input pin is 14 for the clock pulse, pin 13 and 15 are the enable pin and reset pin respectively. These are configured to set the counter count sequentially when the enable and reset pin are grounded to allow pulse input to count. The output pin start from pin 1 to 12. 1 to 11 are the parallel output while pin 12 is $\frac{1}{10}$ of each pin. The pin use 1, 2, 7 and 4, are connected to the display unit through the devices to make the appropriate binary code for the input sequence. And pins 16 and 8 are the power control terminal, which are connected to the positive and negative side of the power supply respectively.

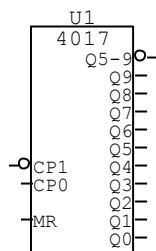

Fig 3.2: pin configures and symbols of 4017

The decade counter sends pulse across it ten outputs whenever its clock received a pulse but in this design it is restricted to four outputs only. The pulse ranges from 1-5v peak to peak.

3.4 DISPLAY UNIT

The display unit uses 74LS47 decoder for a seven segment display which counts for 0-9 digit. The decoder/drive has active low outputs, which are open-collector driver transistor that can

sink a fairly large current (Ramsy, 1983). This is because light emitting diode (LED) readout may require 10 to 40mA per segments, depending on their type and size. The display unit is used to show in decimal values, the number of vehicle that passed through the entrance gate (number of vehicles coming in) and the number of vehicles that passed through the exit gate. The difference between the two gives the number of vehicles in the facility at any time. This serves as counter display. The 74LS47 are low schottky BCD to 7-segment decoder drives consisting of NAND gate, input buffers and seven AND-OR-INVERT gate. They Offer active low, high sink current output for driving indicator directly. Seven NAND gates and one driver are connected in pairs to make BCD data and its complement available to the seven decoding AND-OR-INVERTER gate. The remaining NAND gate and three input buffers provide lamp test, blanking input/ripple-blanking output and ripple-blanking input. The circuit accepts 4-bit binary-coded-decimals (BCD) and depending on the state of the auxiliary input, decodes this data to drive a 7-segment display indicator.

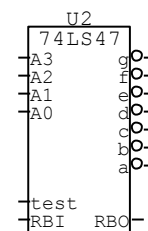

Fig 3.3: the 74LS47 decoder

3.3 THE SWITCHING UNIT

The figure below shows the gate control unit. The PNP and NPN transistor are arranged in such a way that a pair (PNP and NPN) control the opening of the gate through the motor and the other pair reverse the polarity of the motor to rotating it in the opposite direction to close the gate. There is a time interval of 10 seconds between the opening and closing of the gate. The arrangement of the diode serve to protect the transistors from reverse bias polarity and the resistors serve to improve switching time.

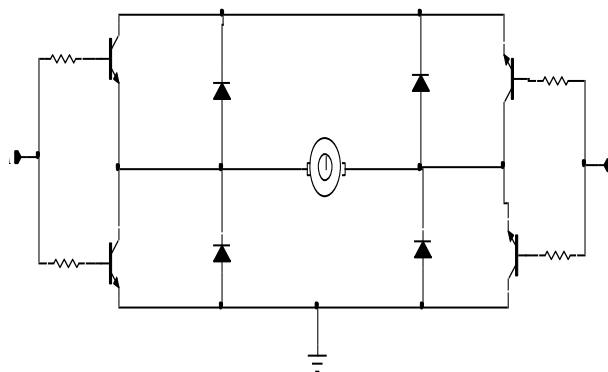

Fig 3.4: switching unit

The motor is used to control the opening and closing of the gate. The electrode (DC) motor used is one that has the ability to

rotate in both directions simply by reversing the polarity. A low signal output from a transistor buffer through the Z80P10 applied to point A bases the NPN and PNP transistor and these causes the motor to rotate in a particular direction. Similarly, a low signal applied to a point B reverse (change) the rotation of the motor in the opposite direction. The control circuit is used for both entrance and exit.

4.0 RESULT AND TESTING

Most often during construction there are some unforeseen problems and it is only during testing of the prototype that some modification can be made, testing and construction puts the engineer in real life situation. Various test were carried out before, during and after the construction has been completed. The multi-meter was extensively used. It was ensured that each of the sub-unit was tested and confirmed that it is functioning perfectly and efficiently, lastly they are all tested individually.

The complete circuit has three basic primary test and two secondary test for the circuit

1. Primary test
2. Continuity test
3. Insulation test

4.1 COMPONENT TESTING

A multi-meter was used to ensure that the various component used for the construction of the design work were in good condition as well as their related values.

4.2 CONTINUITY TESTING

This test was carried out on a Vero board strip line and the connecting wire to ensure continuity of the line i.e. there should be no breaking of line or wires.

4.3 INSULATION TESTING

This is to ensure that there is no leakage current between the insulated conductors. That is resistance should be infinity.

$$R_{IN} = \alpha\Omega$$

SECONDRY TESTING

These are power test and display test. The power test is carried out when the circuit is power attached at the main supply, the output voltage supply to the circuit should meet the required voltage needed to be delivered for the complete circuit. While display testing is carried out by testing the output of the decade counter in orderly manner to give a well arranged sequential output.

TABLE 4.0 COMPONENT TEST AND RESULT OBTAINED

COMPONENT TESTED	RESULT
Resistor	Meter read close to actual resistance to the rated value due to its tolerance
Capacitor	Meter gives a high deflection and slowly return back to initial stage
Transistor	Meter read only when its position terminal is connected to the base of transistor and the negative terminal between emitter and collector
Diode	Meter read in one direction only i.e. from anode to cathode (forward bias) and those not read in reverse direction

The work was tested well and the workability was okay. The output result was successful and when tested it was found out that the system was able to sense an intruding car passing the gate and allowed the next passage, if parking space are available. It also displays the number of car within the parking space.

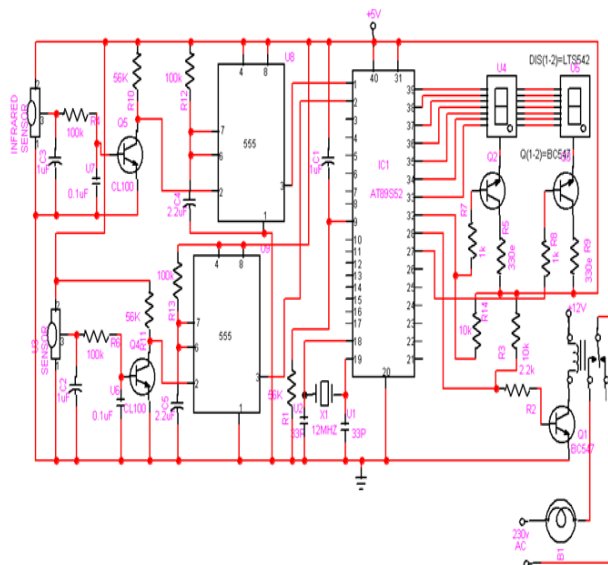

Fig 4.0: complete circuit diagram

5.0 CONCLUSION AND RECOMMENDATION

The total effort put in together in this design of the system was aimed to the particular work, which was attempted to solve the problem of a parking control. However, the design and testing of the system were satisfactory and successfully carried out. The system was found very effective and operates in accordance with the design specifications. Consequently, limitations were encounter, one of which was unavailable of some of the required components in the immediate environment. However, the achievement of the desired purpose was obtained. As a result of that, it can be concluded that this design (automatic car parking) has numerical or several usefulness in the human life.

5.1 RECOMENDATION

This work should be highly considered and recommended because of the several importance, it portrays in human life especially in the area of monitory parking space. However, there is absolute need for modification and integration which can easily improves the design performance. It is therefore advisable to recommend the use of this work in different organization, such as bank, ministries and tertiary institutions etc. It is also recommended that an improvement of the design work is required from three car capacity to a more large capacity. It is also recommended that a more developed means of entrance is required.

5.2 REFERENCE

- i. Paul Horowitz and Windfield Hill (1980). The art of electronics second edition
- ii. D.C Ramsy (1983). Engineering instruction and control
- iii. John Willey (1969). Electronic principles physics model and circuit
- iv. Theraja. B.L and A.K (2002). Electrical technology
- v. Introduction to power electronics Valery Vodovozov (2010)
- vi. Introduction to electronic engineering Valary Vodovozou (2010)
- vii. Digital image processing Huiyu Zhou, Jiahua Wu, Jiangovo Zhang (2010)
- viii. Electronic device and circuit, second edition Jimme J. Cathey (2002)